

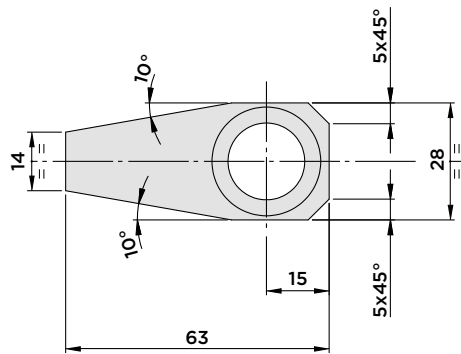

# SERIE SRA20

## • ZUBEHÖR

### SPANNARM 01.SRA20

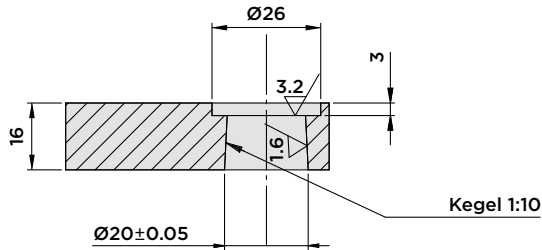

### SPANNARM 07.SRA20

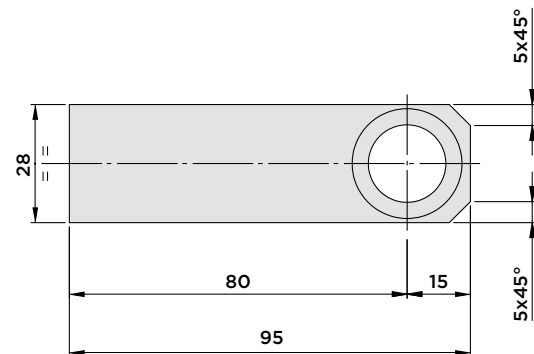
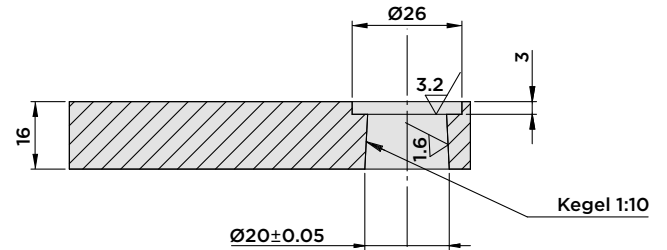

### SPANNARM 11.SRA20

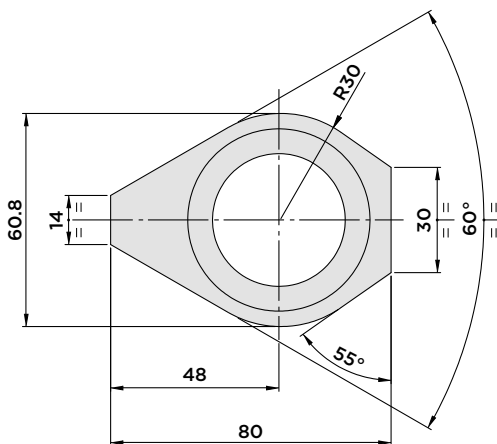
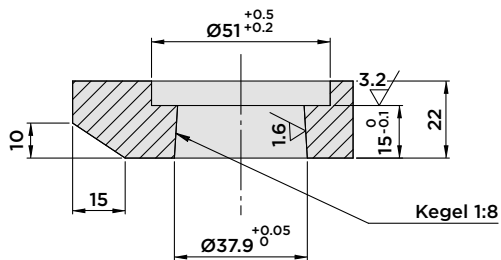

### SPANNARM 12.SRA20

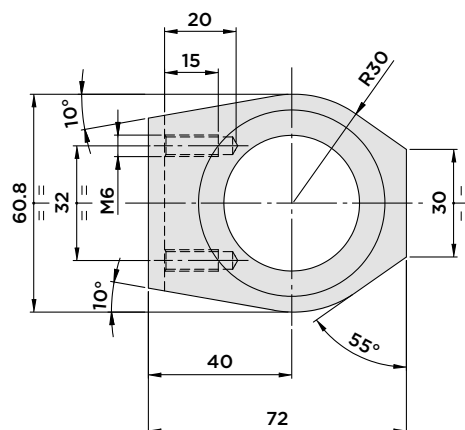
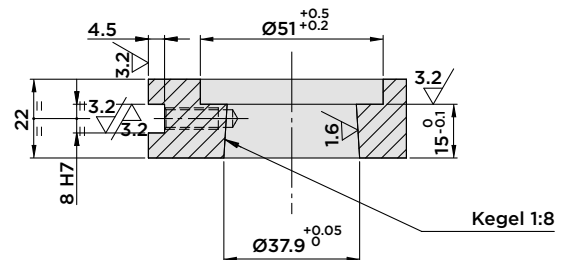

Werkstoff: C45



HYDROBLOCK