

IRC4P 32.110M

LONG STROKE ANTIVIBRATION WORK SUPPORT

WITH **DOUBLE-ACTING CARTRIDGE BODY**

MAX. OPERATING PRESSURE = 500BAR

- A** : Extension
- B** : Retraction
- C** : Clamping
- V** : Aeration

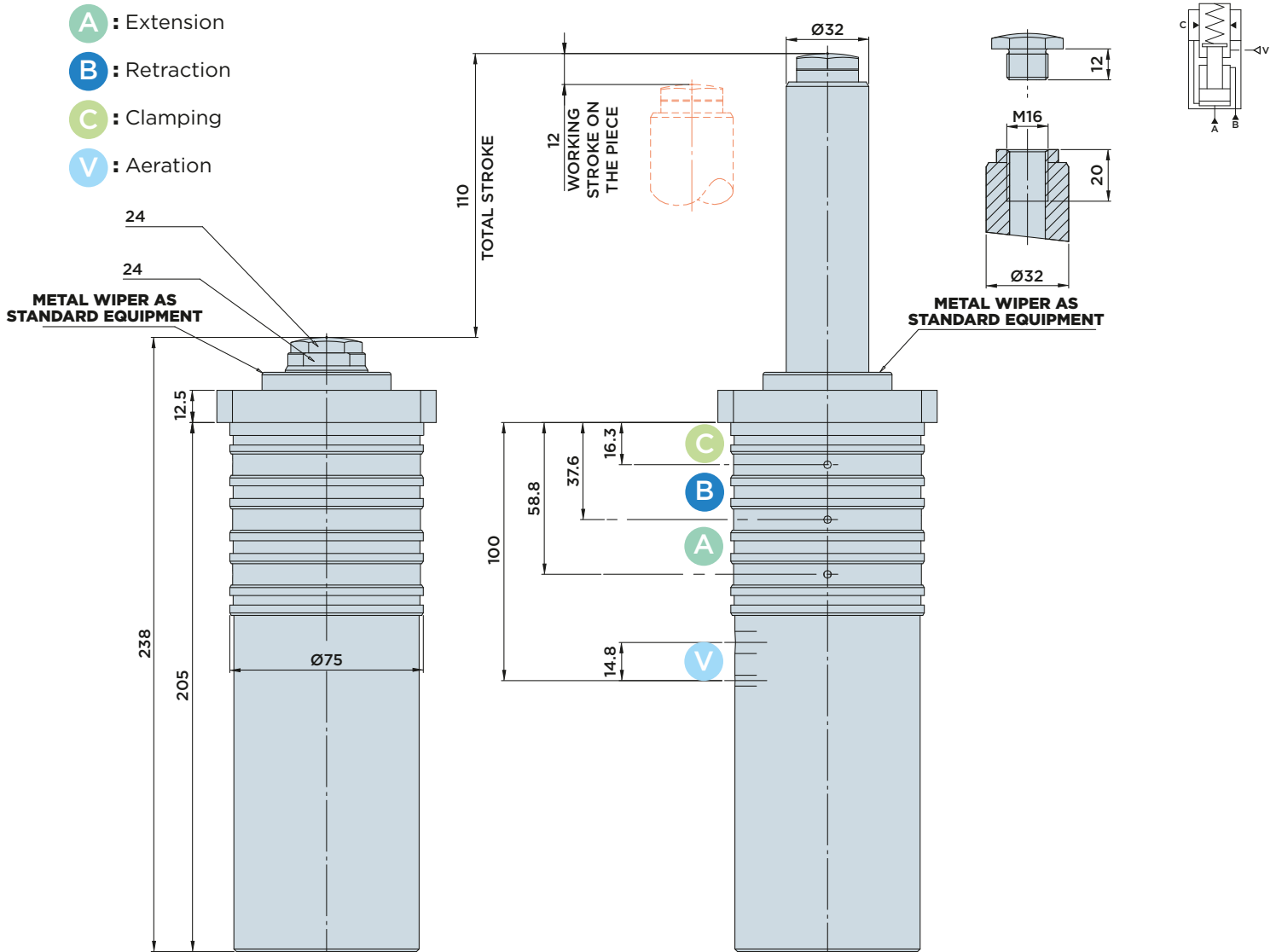

INSTALLATION DIMENSIONS

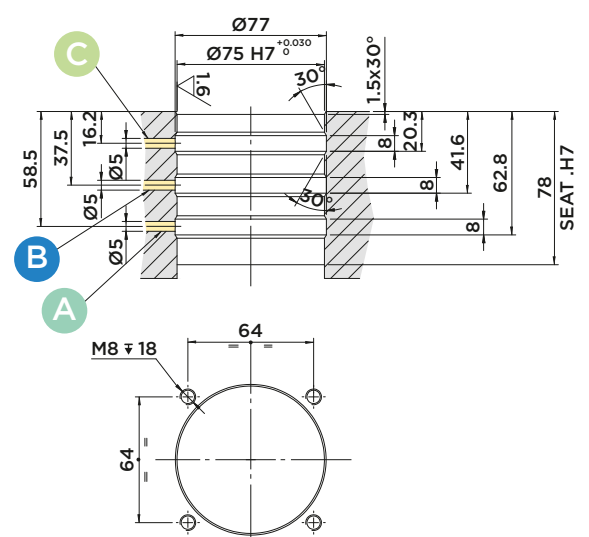

Included in the scope of supply:

- Mounting screws M5x25 DIN 912/12.9 grade
- Sintered filter

Material:

- Rod: Case-hardened steel, ground
- Body: Free machining steel, nitrocarburized



HYDROBLOCK