

CPV01

VALVE PROTECTION CARTRIDGE

- A:** CPV housing
- B:** CPV bolt
- C:** Fastening ring/hexagon socket screw, depending on cylinder type

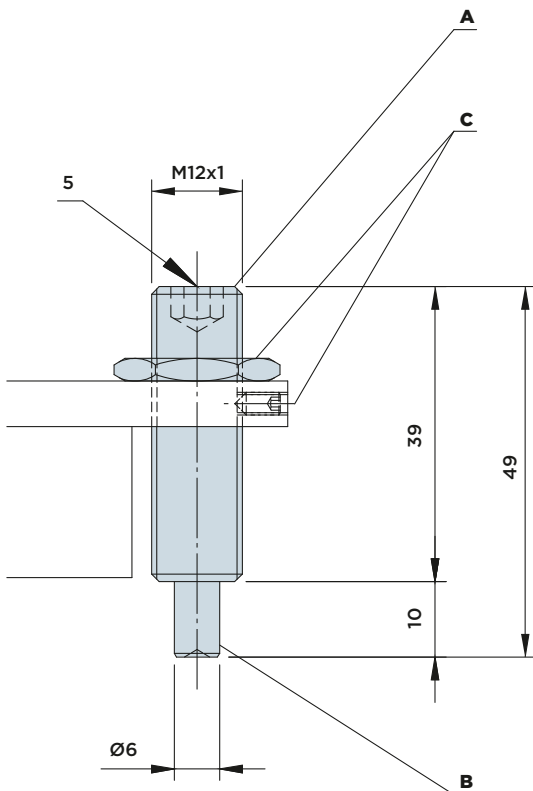

Upon request, the valve protection cartridge is available for the entire swing clamp cylinder series.

With the CPV01 valve protection cartridge the final user can perform clamping operations without any workpiece being mounted in the fixture for a functional check or for cleaning purposes. In this case, there is no risk of damage to the VCS clamp arm position control valve caused by excess stroke.

Installing the valve protection cartridge:

The valve protection cartridge is factory-mounted to HYDROBLOCK cylinders when ordered as an option.

However, retrofitting can also easily be carried out by the end user on the basis of corresponding mounting instructions. A simple M12x1 threaded seat is required on the clamp arm plate for mounting the valve protection cartridge for clamp position control valves.

ADJUSTMENT OF THE VALVE PROTECTION CARTRIDGE:

To adjust the valve protection cartridge for clamp arm position control valves, proceed as described in the instructions 1 to 4 for the adjustment of the clamp arm position control valve. Use the 5 mm hexagon socket provided at the threaded cartridge end for this purpose. Upon completion of the adjustment, the pressure switch will indicate that the compressed air circuit is closed and enables the machine cycle start.

The bolt of the valve protection can compensate an excess stroke of up to 10 mm and re-establish the starting conditions as soon as the cylinder has reached the unclamping position. **Make sure that no stroke over 10 mm is performed during clamping operations without workpiece.** We recommend mounting the swing clamp cylinders such as to ensure that the clamp arm in clamping position is close to the lower limit stop of the piston. In this case, the workpiece is properly and reliably clamped and perfect operation of the valve protection cartridge is guaranteed.

