

SERIE SRA16

• ACCESSORI

STAFFA 01.SRA16

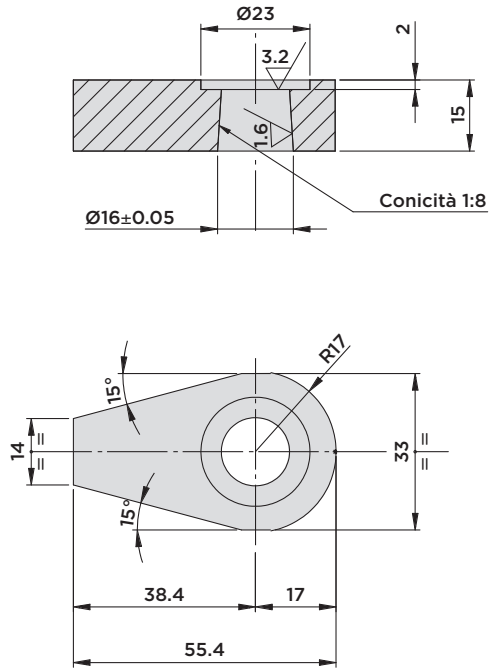

STAFFA 07.SRA16

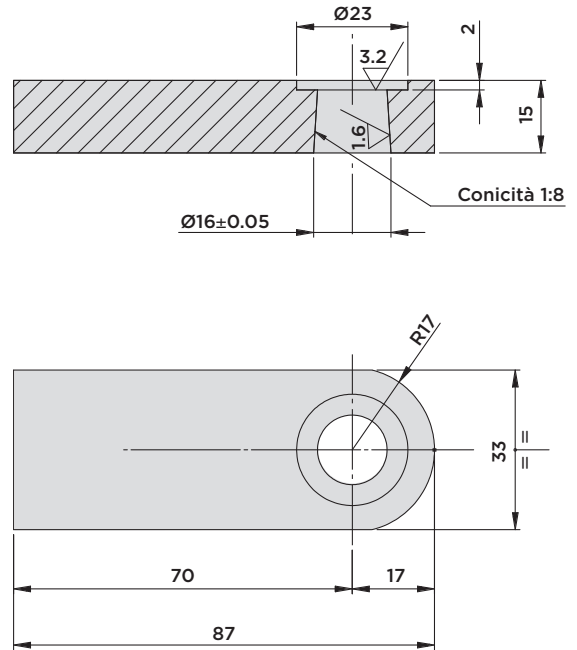

STAFFA 11.SRA16

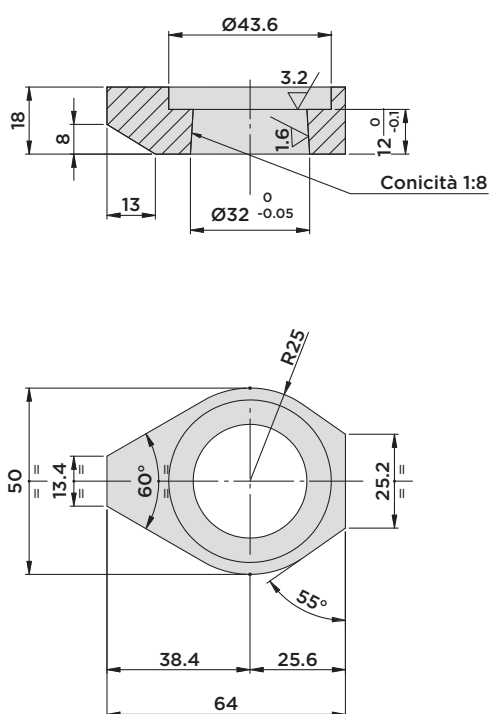

STAFFA 12.SRA16

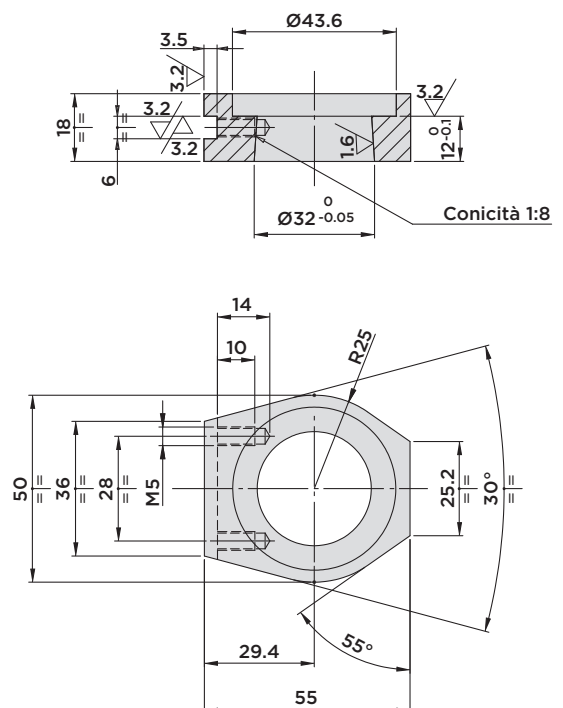

Materiale: C45



HYDROBLOCK