

SRA

SELF-ADJUSTING SWING CLAMP CYLINDERS



HYDROBLOCK

SRA SELF-ADJUSTING SWING CLAMP CYLINDERS

PATENT-REGISTERED SRA CYLINDERS

Double-acting swing clamp cylinders with integrated work support of the SRA series have been developed for clamping points that can hardly be reached by the conventional combination of cylinder and separate hydraulic work support. Their special mechanical design minimizes the contact force exerted by the cylinder on the workpiece. Depending on the application, this force ranges between 50 and 250N. Minimal forces acting on the workpiece are produced with horizontal cylinder application. No force at all is exerted by the clamp arm on the work support. A reliably high supporting force is thus available to absorb the thrust forces of the tools generated during the machining process. A precise control of the hydraulic system minimizes workpiece deformation. To ensure smooth running and minimal deformation of the machined workpiece, the SR self-adjusting swing clamp cylinders with integrated work support are not equipped with the HYDROBLOCK compensation system. Bores in the clamp arm and in the cylinder counterpart are sufficient to precisely guide the clamp arm and to ensure that it reaches the correct clamping point without any cost-intensive accessory equipment being required.

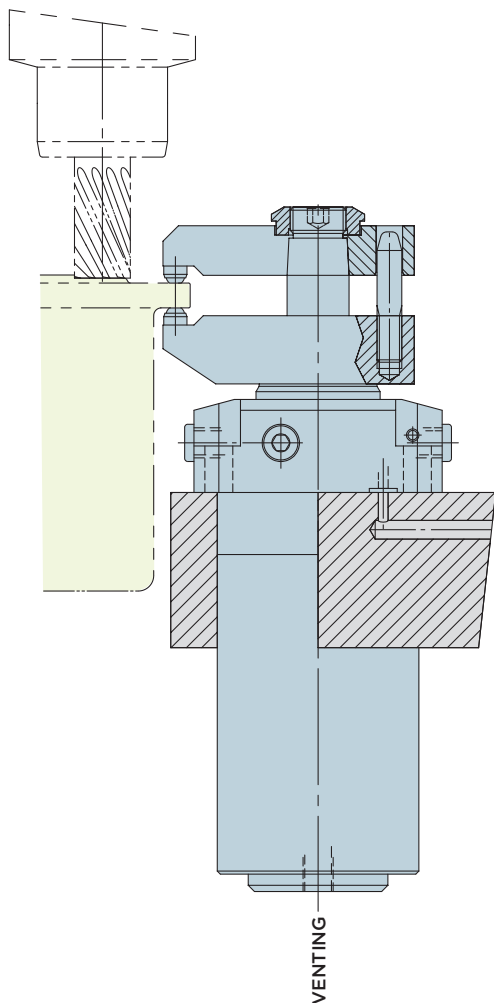

SUPPLY:

To ensure smooth operation of the SR self-adjusting swing clamp cylinders, the supply flow must be controlled to values below the maximum admissible flow rate. Excessively high flow rates will affect the operation of the clamp arm and the work support, i.e. they will be blocked before having reached the maximum stability. The clamp arm is thus approached too fast and causes higher workpiece deformation.

ATTENTION: In view of the area ratio of 1:2.8/1:3.3 of SRA cylinders, the unblocking conditions of the check valves, if any, must be taken into consideration. Failure to observe this instruction may cause dangerous overpressure in the hydraulic line.

VENTING:

The pressure in the cylinder chambers increases during operation. If no sufficient venting is ensured, fluids, dust and chips could be sucked in. To ensure proper operation of the SRA cylinders, the pneumatic line must be free and efficiently protected against the penetration of fluids, contaminant and chips.



SRA FDSV SELF-ADJUSTING SWING CLAMP CYLINDERS

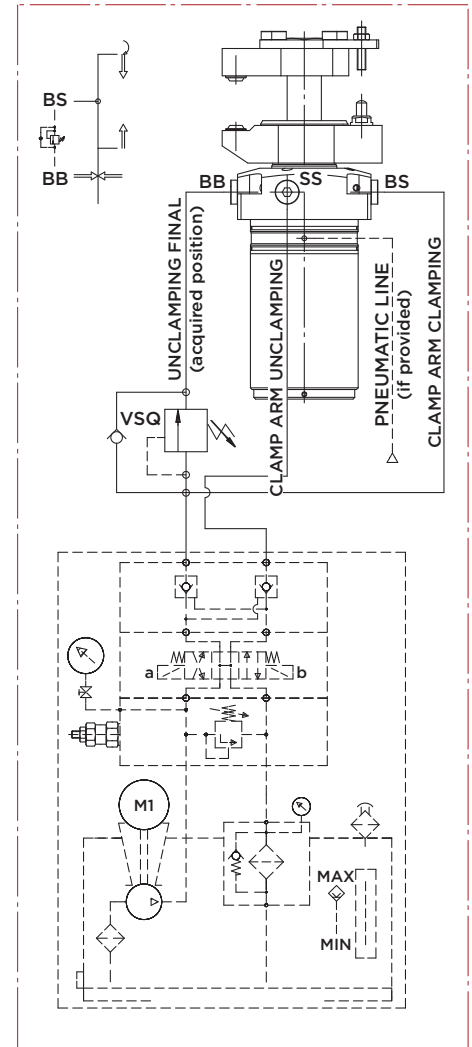
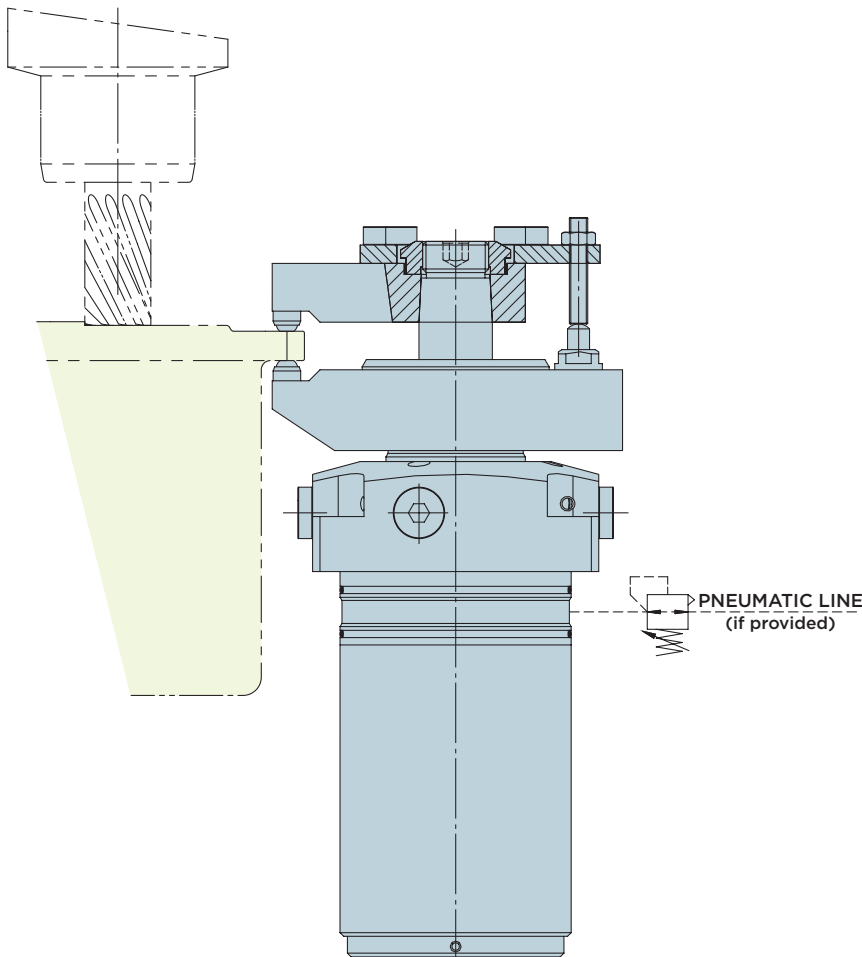

HYDROBLOCK has always been committed to providing maximum product quality and unparalleled functionality considering the most varied operating conditions and the state-of-the-art in machining technology. The new SRA_FDS/SRA_FDSV swing clamp cylinders are the fruit of extensive technical know-how and the ambition to offer our customers compact and innovative products meeting the most challenging requirements in terms of reliability and safety for systems integrated into modern robot-assisted plants.

THE NEW SWING CLAMP CYLINDER STANDS OUT FOR:

- 1) Innovative swing mechanism of even higher resistance.
- 2) New pneumohydraulic concept for the positioning on the workpiece to be clamped.

- 3) Plus in safety during operation thanks to a double pneumatic signal for continuous monitoring of the clamp arm position (open or closed) relative to the workpiece. Machining of the clamped workpiece is thus performed with absolute safety and reliable robot-assisted unloading of the unclamped workpiece is ensured.

PNEUMATIC LINE

The pneumatic line for monitoring the open cylinder position and controlling the pneumatic approach force signals the open cylinder state as soon as the line is closed. During the clamping process, this line acts on the internal pistons to facilitate releasing of the seals, to compensate the weight of the moving mechanical parts thus reducing the forces acting on the clamped workpiece and the resulting deformation.



SRA20 FD SELF-ADJUSTING SWING CLAMP CYLINDERS

EFFECTIVE CLAMPING FORCE

CLAMPING FORCE CALCULATION

Effective clamping force:

$$F = \frac{P}{71,4 + 0,0079 \cdot l} \leq F_{adm} \quad [\text{kN}]$$

Maximum admissible clamping force*:

$$F_{adm} = \frac{90}{l} \quad [\text{kN}]$$

Maximum admissible operating pressure:

$$p_{adm} = \frac{6430}{l} + 7,14 \leq p_{max} \quad [\text{bar}]$$

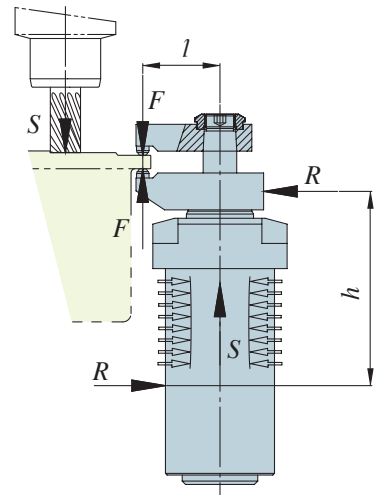

l = Clamp arm length [mm] p = Pressure [bar]

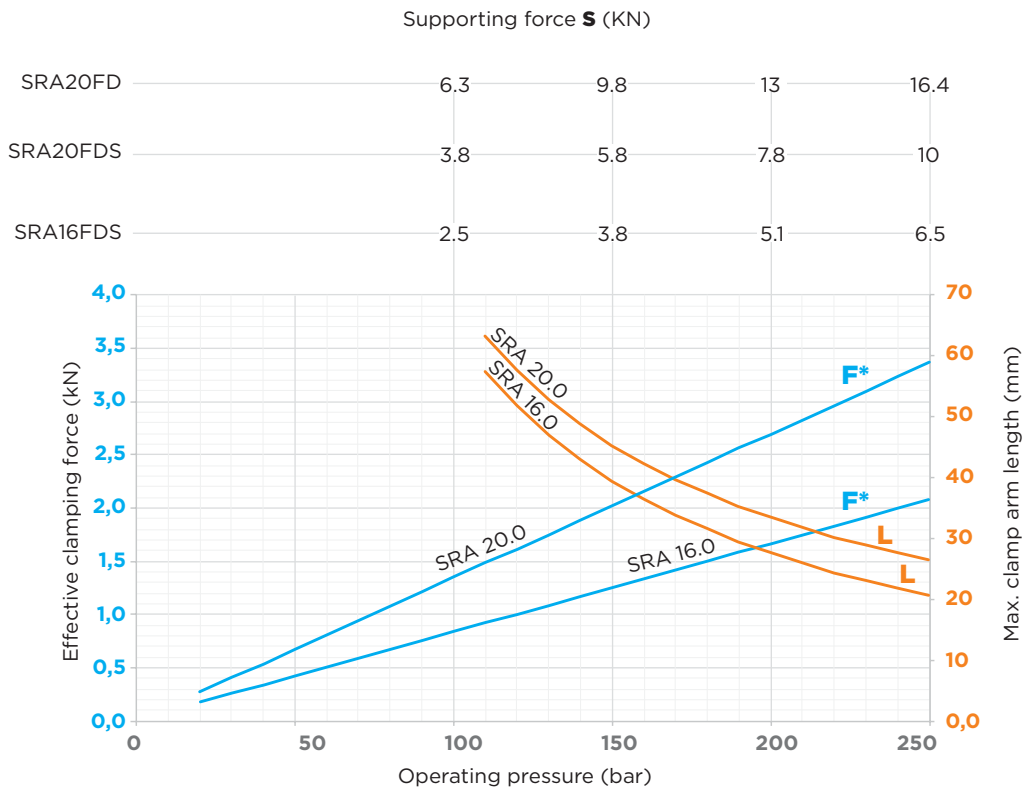

* After determination of the clamping arm length l , the maximum clamping force F must not exceed the indicated value.



SRA16.0 FDS

DOUBLE-ACTING SWING CYLINDER WITH INTEGRATED WORK SUPPORT,

SELF-ADJUSTING, WITH **UPPER FLANGE**

MAX. OPERATING PRESSURE = 250BAR

BS : Clamp arm clamping

SS : Clamp arm unclamping

BB : Sleeve clamping

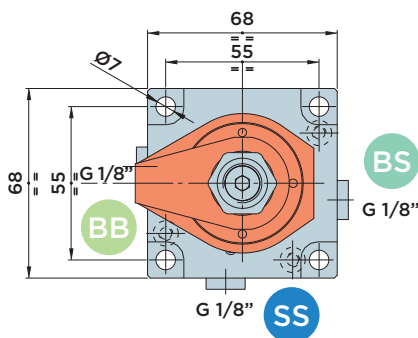
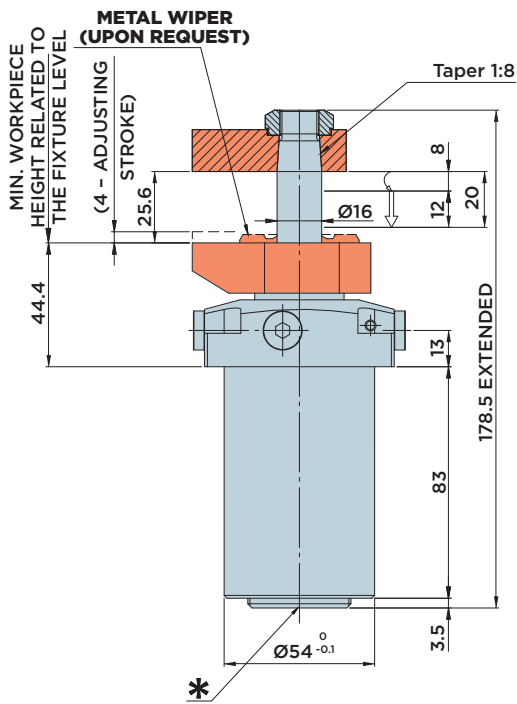
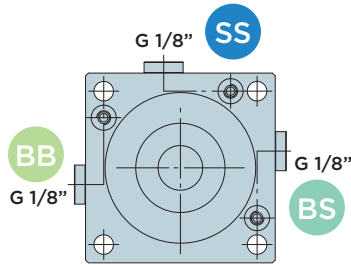

INSTALLATION DIMENSIONS WITH O-RING CONNECTION

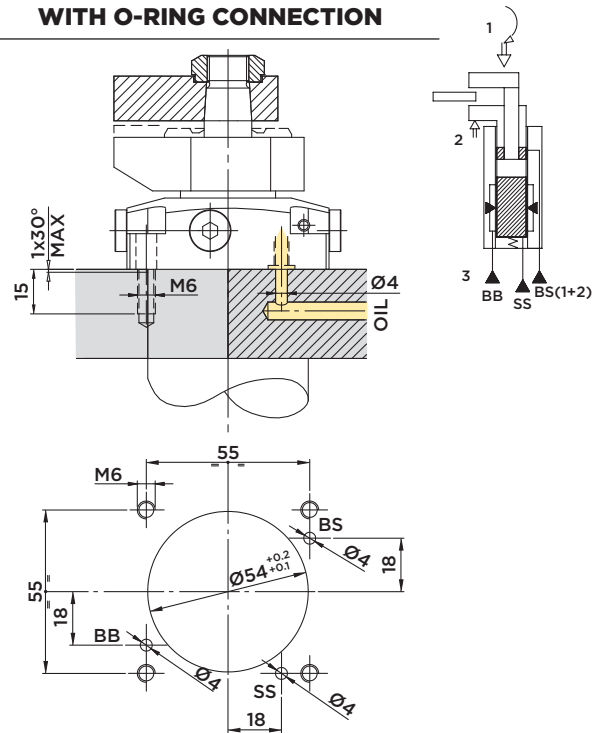

* Venting: We recommend installing a connection with a vent line leading into an area that is free from liquids and chips.

Included in the scope of supply:

- Mounting screws M6x25 DIN 912/12.9 grade
- O-Rings Ø6.07x1.78

Material:

- Piston/rod: Case-hardened steel, ground
- Body: Free machining steel, nitrocarburized

Note:

Max. admissible flow rate: 2,5 l/min
Clamping force diagram, see page 112

	STROKE mm	EFFECTIVE PISTON AREA		TOTAL OIL VOLUME	
		CLAMP.	UNCLAMP.	CLAMP.	UNCLAMP.
		Cm ²		Cm ³	
TOTAL	20				
SWINGING	7				
CLAMPING	13	1.13	3.14	2.3	6.3

SRA16 SERIES

• ACCESSORIES

CLAMP ARM 01.SRA16

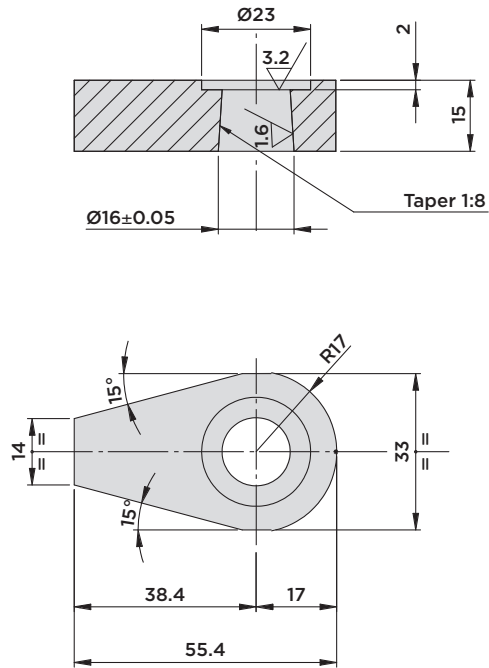

CLAMP ARM 07.SRA16

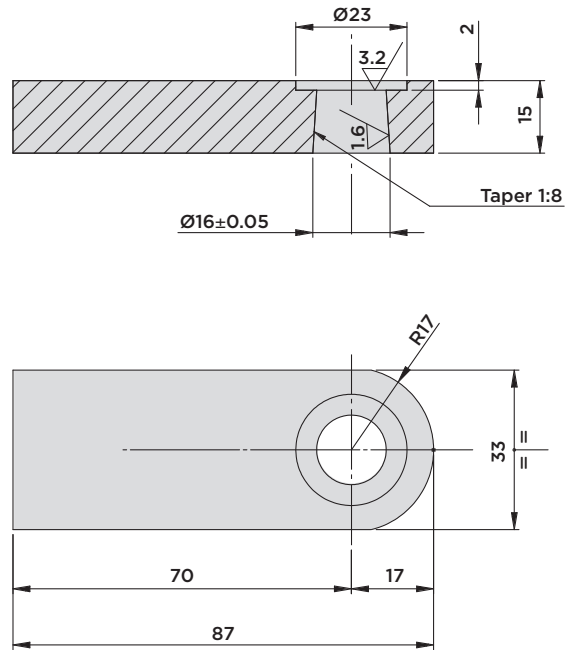

CLAMP ARM 11.SRA16

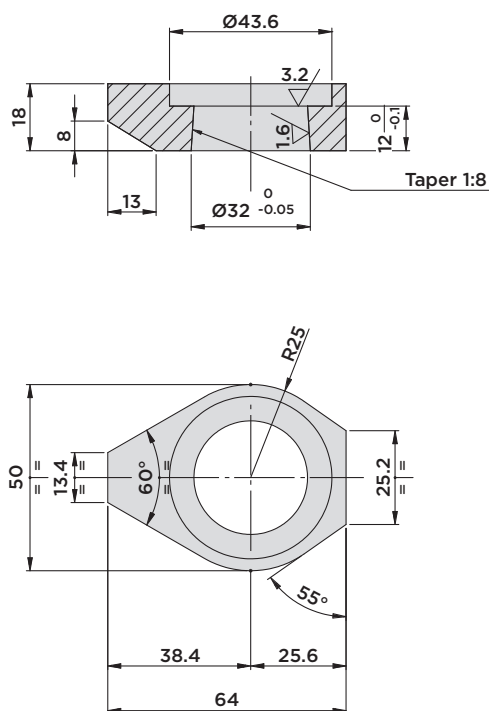

CLAMP ARM 12.SRA16

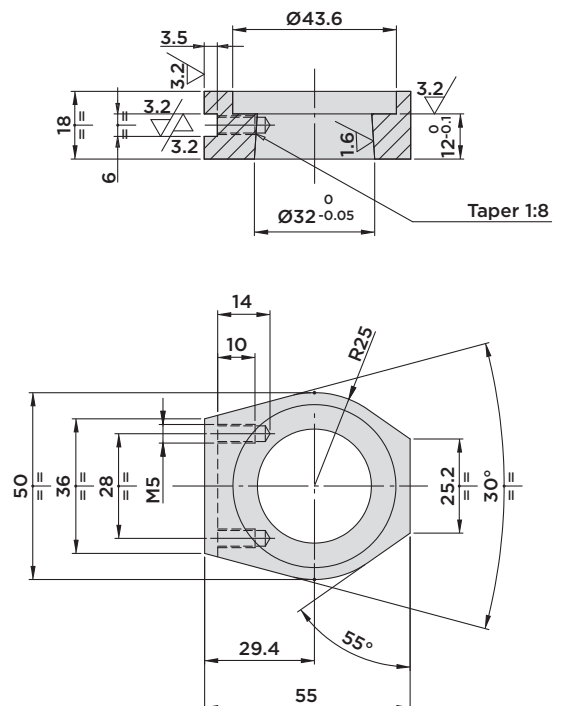

Material: C45



HYDROBLOCK

SRA20.0 FD

DOUBLE-ACTING SWING CYLINDER WITH INTEGRATED WORK SUPPORT,

SELF-ADJUSTING, WITH **UPPER FLANGE**

MAX. OPERATING PRESSURE = 250BAR

BS : Clamp arm clamping

SS : Clamp arm unclamping

BB : Sleeve clamping

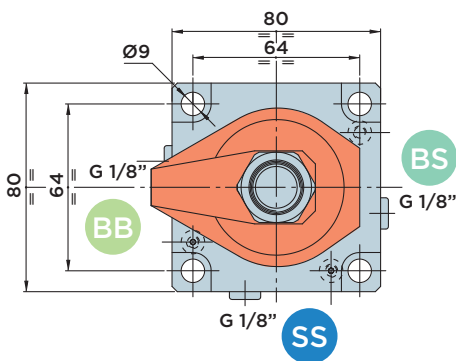
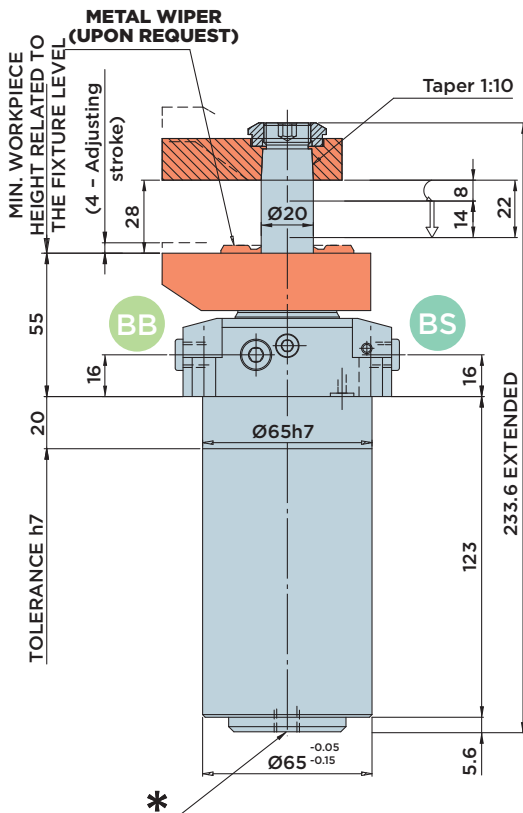

INSTALLATION DIMENSIONS WITH O-RING CONNECTION

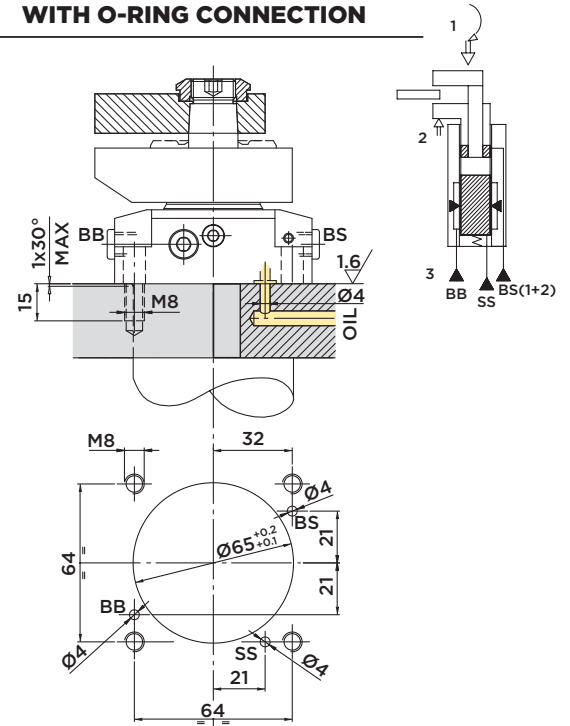

* Venting: We recommend installing a connection with a vent line leading into an area that is free from liquids and chips.

Included in the scope of supply:

- Mounting screws M8x30 DIN 912/12.9 grade
- O-Rings Ø6.07x1.78

Material:

- Piston/rod: Case-hardened steel, ground
- Body: Free machining steel, nitrocarburized

Note:

Max. admissible flow rate: 2,5 l/min
Clamping force diagram, see page 112

STROKE mm	EFFECTIVE PISTON AREA		TOTAL OIL VOLUME	
	Cm ²		Cm ³	
TOTAL	22	CLAMP. UNCLAMP.	CLAMP. UNCLAMP.	
SWINGING	8	1.38 4.52	3	9.9
CLAMPING	14			



HYDROBLOCK

SRA20 SERIES

• ACCESSORIES

CLAMP ARM 01.SRA20

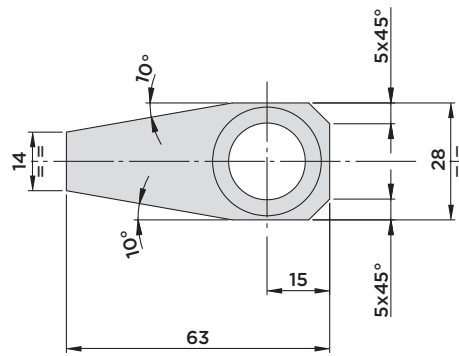
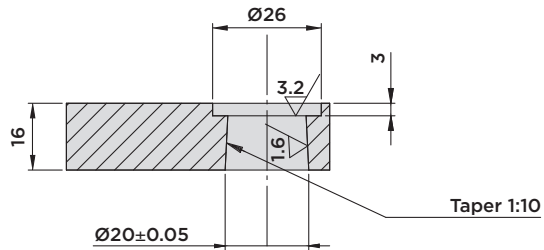

CLAMP ARM 07.SRA20

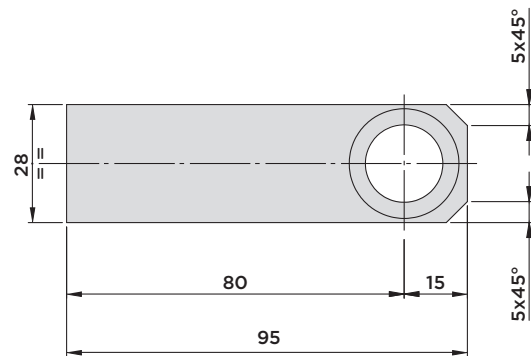
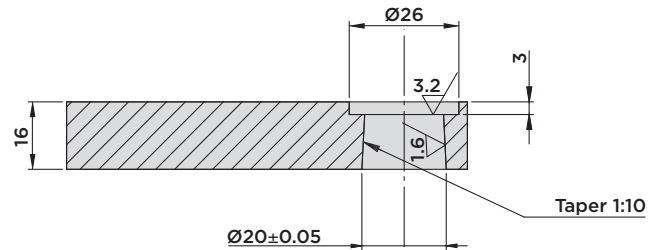

CLAMP ARM 11.SRA20

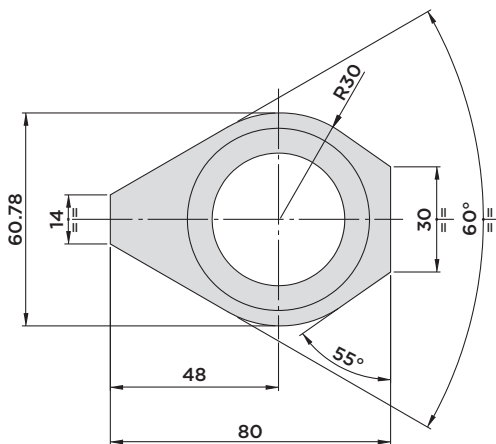
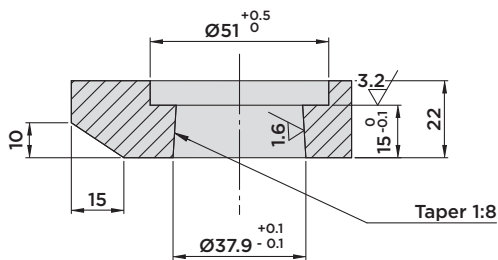

CLAMP ARM 12.SRA20

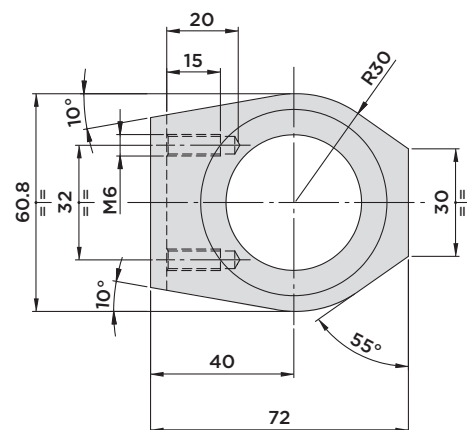
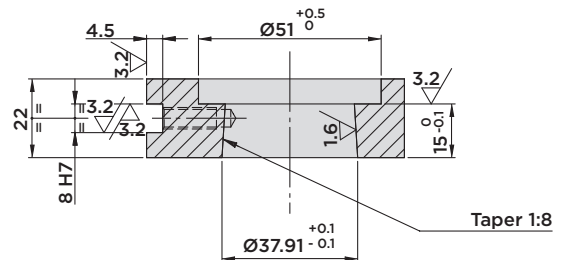

Material: C45



HYDROBLOCK

SRA20.0FDSV

MAX. PRESSURE = 250BAR

DOUBLE-ACTING SWING CYLINDER WITH INTEGRATED WORK SUPPORT, SELF-ADJUSTING,
WITH **UPPER FLANGE** AND **CLAMP ARM POSITION CONTROL VALVE**

- BS** : Clamp arm clamping
- SS** : Clamp arm unclamping
- BB** : Sleeve clamping

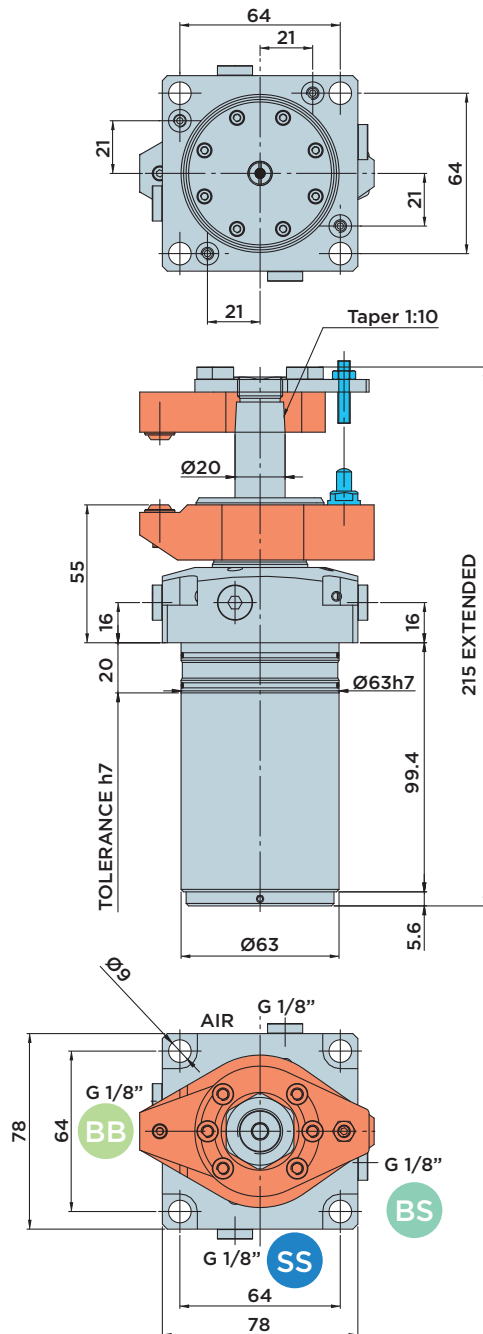

Options:

The swing clamp cylinder is also available without VCS10/VCS13 clamp arm position or workpiece control valve.
Order code SRA20.0FDSV

INSTALLATION DIMENSIONS WITH O-RING CONNECTION

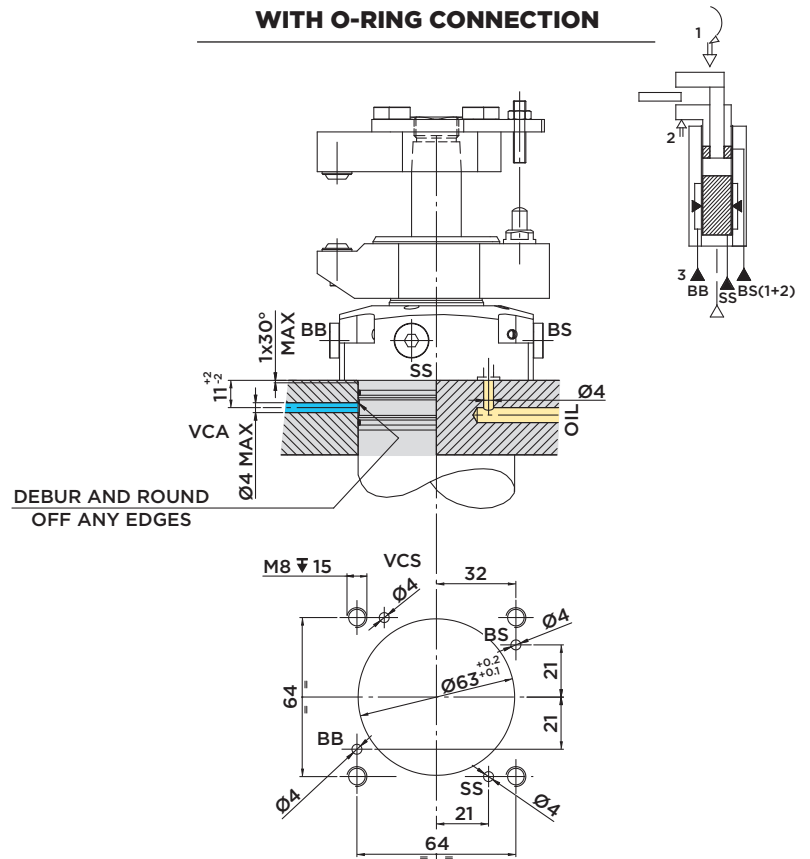

Included in the scope of supply:

- Mounting screws M8x30 DIN 912/12.9 grade
- O-Rings Ø6.07x1.78

Material:

- Piston/rod: Case-hardened steel, ground
- Body: Free machining steel, nitrocarburized

Note:

Max. admissible flow rate: 2,5 l/min
Clamping force diagram, see page 112

STROKE mm	EFFECTIVE PISTON AREA		TOTAL OIL VOLUME	
	Cm ²		Cm ³	
TOTAL	22			
	CLAMP.	UNCLAMP.	CLAMP.	UNCLAMP.
SWINGING	8			
	1.38	4.52	3	9.9
CLAMPING	14			



HYDROBLOCK