

IRFM 16.10A

CILINDRO IRRIGIDITORE ANTIVIBRANTE PRESSURIZZATO CON **CORPO FILETTATO**

PRESSIONE MASSIMA = 500BAR

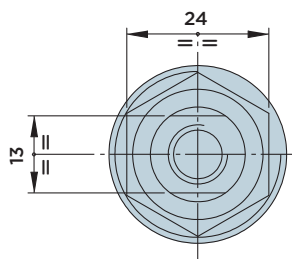
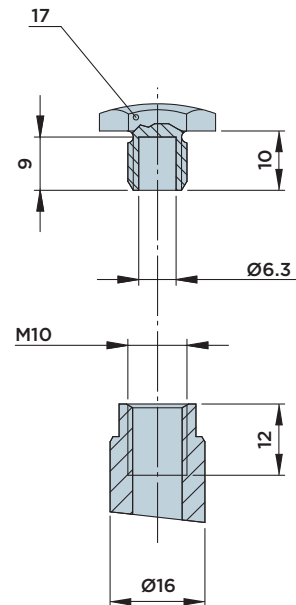
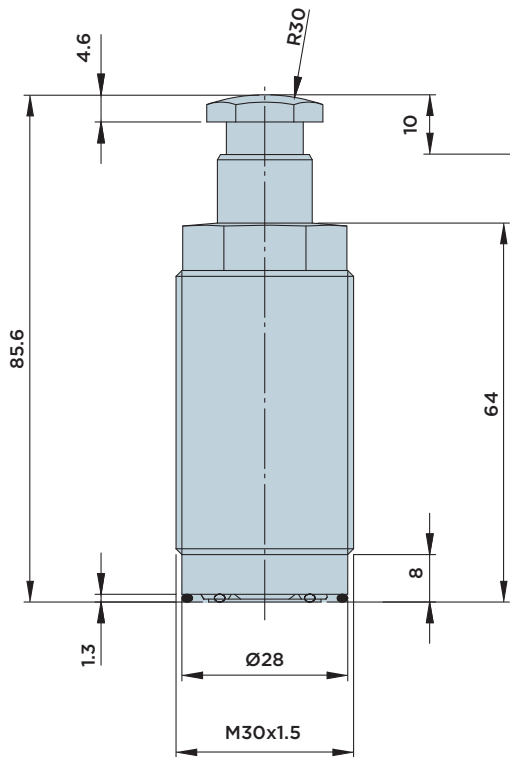

DIMENSIONI INSTALLAZIONE

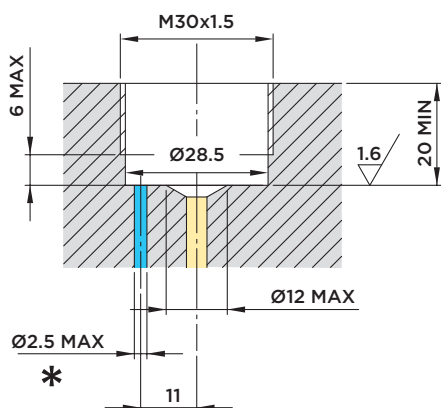

* Alimentazione pneumatica: vedi pag.281.

DIAGRAMMA FORZA/PRESSIONE/FLESSIONE

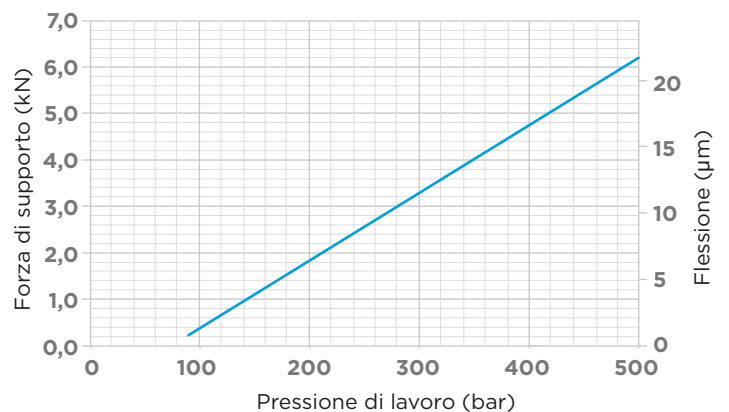

Note:

Flusso volumetrico massimo ammesso in alimentazione cilindro 1.5 l/min.

Forza di accostamento:

- Standard 15÷30 N
- A richiesta 8÷20 N (codice ordinazione IRFM16.10AL)

Forniti a corredo:

- O-Ring Ø14x1.78
- O-Ring Ø23.52x1.78

Materiali:

- Stelo: acciaio da cementazione indurito e rettificato.
- Corpo: acciaio da macchine automatiche nitrocarburato.



HYDROBLOCK